

# INSTALLATION AND OPERATING INSTRUCTIONS FOR REPLACEMENT KIT

**WARNING:** Replacing any of the fixture system components such as the lamps, lamp holders, ballasts, fixture components, mounting or connections with other than the originally approved components, may void the UL listing for the fixture combination. If a question exists as to the proper component replacement required to maintain the UL listing for the fixture system, the fixture manufacturer, or his representative, should be contacted.

## DESCRIPTION

The Replacement Kit consists of a ballast with input voltage connections rated for 120, 208, 240 or 277 volts, or a ballast rated for 480 volts, capacitor, mounting brackets and nuts and bolts which permit field replacement of a ballast in a High Intensity Discharge type lamp fixture.

The mounting brackets may be used by drilling holes in them to match the existing holes in the fixture so that the ballast may be securely mounted to the fixture. Nuts and bolts are supplied for mounting the brackets to the ballast by using the pre-drilled holes in the brackets.

## SAFETY REQUIREMENTS

Safe and reliable operation of H.I.D. ballasts requires that:

1. The ballasts must be applied only in fixtures and equipment which have U.L Listing or the ballast and fixture combination in accordance with applicable U.L. safety standards, such as U.L. 48-Electric Signs and U.L. 1572 High Intensity Discharge Lighting Fixtures.
2. The ballast and fixture must be mounted, assembled and wired in conformance with the National Electrical Code, applicable state, and municipal codes, as well as with the specific U.L. safety standards for the particular fixture or equipment and its intended working environment, such as U.L. 844-Electric Lighting Fixtures for use in hazardous locations, and U.L. 1572 High Intensity Discharge Lighting Fixtures.

When the multivolt ballast kit is used, connect the ballast lead rated for the voltage in the installation (unused ballast voltage connections must be isolated and insulated from ground and each other). IF it is necessary to drill holes in the brackets, this should be done before they are bolted to the ballast. Ground the ballast core (See Grounding Section)

Replacement of a ballast with one that has a different catalog number (constitutes a revision in the original U.L. listing for that particular fixture. It is the responsibility of the person making the replacement to assure safe and proper installation and operation If the new ballast does

not have the same catalog number as the ballast being replaced, the installer must obtain proper application and installation recommendations from the fixture manufacturer.

## BRACKET ATTACHMENT

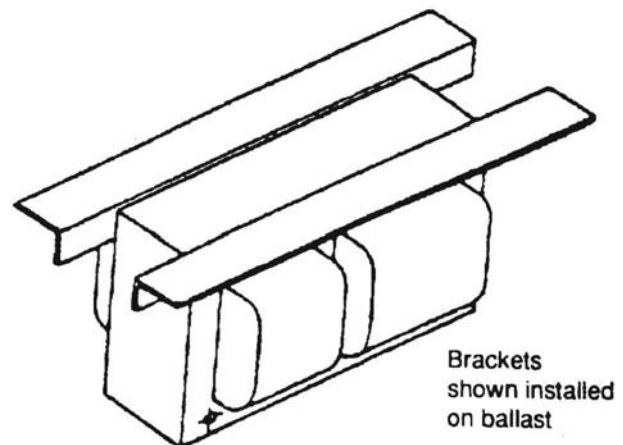

## STEPS TO INSTALL YOUR REPLACEMENT KIT

1. **CAUTION:** If any repairs or alterations to the fixture or its components are undertaken, the installer must contact the fixture manufacturer for proper instructions. This includes but not limited to the voltage and temperature rating of the hook-up cable; the pulse rating of sockets used for H.P.S. lamps; other detailed specifications for components that are part of the original U.L. listing.
2. **CAUTION:** Disconnect power to the fixture.
3. Remove old ballast and capacitors (Also remove the starting aid used with a HPS ballast).
4. Install new ballast and capacitors. (Install starting aid for HPS ballast). If mounting brackets are required, bolt them securely to the core and coil with the nuts and bolts provided. If it is necessary to drill holes in the brackets, this should be done before they are bolted to the ballast. Ground the ballast core (See Grounding Section).

## STEPS TO INSTALL YOUR REPLACEMENT KIT

5. For multivolt replacement kit, connect the appropriate leads to the power supply. Use one voltage lead from the four supplied (120, 208, 240,277) and one common lead. Connections must be made electrically and mechanically secure and insulated from ground. Insulate the three unused voltage leads to prevent grounding or shorting to each other with high temperature (150" C. min.) glass reinforced electrical tape or a suitable insulated crimp connector.
6. For 480 volt replacement kit, connect the appropriate leads to the power supply. Connections must be made electrically and mechanically secure and insulated from ground.
7. Connect the capacitor lead(s) from the ballast to the capacitor(s). Connect the lamp lead to the center pin of the socket. Connect the second common lead to the shell of the socket. (Connect starting aid leads into circuit for HPS ballasts). See connection diagram on ballast for proper wiring.

Non-PCB capacitors have internal pressure type interrupters which activate when an internal short occurs. Upon activation, the capacitor cover expands interrupting the electrical connection. A minimum expansion clearance of one-half inch shall be provided between the capacitor terminals and/or assembled wire connections and a plane perpendicular to the capacitor terminal.

8. Recheck for proper wiring. Secure component mounting and proper lamp wattage and type before closing the fixture. Always refer to the ballast nameplate for specific wiring instructions and lamp rating.
9. Turn on the power only after assuring all safety requirements have been fulfilled.

## OTHER INSTALLATION REQUIREMENTS

The replacement kit includes mounting brackets and bolts which may be reworked to match the old ballast mounting position. Be sure that the brackets secure the components in the fixture so that installation and vibration will not change the location of these components.

Special care must be taken to assure adequate spacing of electrical parts. Wires must not be

pinched. Live parts must be adequately spaced and extra terminals or leads insulated from each other and from ground.

## GROUNDING

**CAUTION:** A ground connection must be made to all ballasts to avoid possible personal injury and damage to the fixture and installation. Electrical grounds should comply with the National Electrical Code. ANSI Standards or local electrical Codes where appropriate.

Core and coils are insulated with a varnish like material. This material must be penetrated at the point where the ground connection is made to insure a good connection. This connection can be made when mounting the ballast to the fixture by using a star washer in combination with one of the mounting bolts or by using self-tapping screws which thread directly into one of the core mounting holes.

## TROUBLE SHOOTING

**CAUTION:** The following trouble shooting procedures are to be performed only by a qualified electrician. When checking connections or interchanging components, the power must be turned off.

If a malfunction occurs:

1. Be sure all connections to the line, capacitor (if required) and lamp have been properly made.
2. Measure fine voltage to determine whether it is within tolerance specified for the ballast being used.
3. Check for blown fuse or tripped circuit breaker. If power interruption has occurred, check each fixture component for possible shorting or grounding.
4. Try lamp on another ballast known to be operating properly or try another lamp on the ballast in question. Make sure lamp and ballast are properly matched in terms of wattage and type.
5. In the High Pressure Sodium Lamp system, be sure lead marked lamp on starting aid is connected to center eyelet of lamp socket.
6. In the High Pressure Sodium Lamp system, to determine if starting aid is faulty, test by substituting another starting aid.