



50 to 5000 VA

Contents

Overview	11.2
Dimensional Drawings	11.4
Wiring Diagrams	11.5
Selection Charts	
240/480 V	11.3
208/277 V	11.3
415/600 V	11.3

Products

- 50 VA through 5,000 VA*

Applications

- For control panels, conveyor systems, machine tooling equipment, commercial sewing machines, pumping system panels and commercial air conditioning applications

Specifications

- Open core and coil design
- Cores of high quality electrical steel
- Machine wound copper coils
- 50/60 Hz operation
- **Proudly Made in U.S.A.**

Features, Functions, Benefits

- Slotted mounting holes for quick and easy mounting
- Terminal jumpers for quick series/parallel connections on units with dual windings (panel type)
- Permanently affixed wiring diagram

Standards

- Built in accordance with NEMA, ANSI and UL standards

***Options and Accessories**

- 2-pole (200 Series) and 3-pole (300 Series) fuse block designs available
- Finger-safe terminal design (400 Series) available (CE Marked)
- See UniCap section for other voltage combinations

Industrial Control – Core and Coil

Group 1: Panel Type

55°C Temperature Rise for 50 VA – 250 VA • Class 105°C Insulation • 50/60 Hz • Fuse Clip Provided
80°C Temperature Rise for 300 VA – 350 VA • Class 130°C Insulation • 50/60 Hz • Fuse Clip Provided

Group 1: Terminal Type

115°C Temperature Rise for 500 VA – 5000 VA • Class 180°C Insulation • 50/60 Hz

VA	Catalog Number	Fig.	Depth A (in.)	Length B (in.)	Height C (in.)	Mounting D	Mounting Center E	Mounting Center F	Mounting Slot GXH	Wiring Diagram	Est. Ship Wgt. (lbs.)
240/480, 230/460, 220/440 V – 120, 115, 110 V											
50	636-1111-000	10	3.31	3.00	2.50	2.88	1.88	2.50	.203 x .75	1A	2.5
75	636-1121-000	10	3.56	3.38	2.88	3.00	2.25	2.81	.203 x .50	1A	3.5
100	636-1131-000	10	3.75	3.38	2.88	3.00	2.25	2.81	.203 x .50	1A	3.75
150	636-1141-000	10	4.31	4.50	3.81	4.38	3.00	3.75	.203 x 1.13	1A	6.5
200	636-1151-000	10	4.56	4.50	3.81	4.38	3.00	3.75	.203 x 1.13	1A	7.5
250	636-1161-000	10	5.00	4.50	3.81	4.38	3.00	3.75	.203 x 1.13	1A	9.0
300	636-1171-000	10	4.56	4.50	3.81	4.38	3.00	3.75	.203 x 1.13	1A	7.5
350	636-1181-000	10	5.00	4.50	3.81	4.38	3.00	3.75	.203 x 1.13	1A	9.0
500	636-1191-000	11	5.50	4.50	3.81	4.38	3.00	3.75	.203 x 1.13	1B	11.0
750	636-1201-000	11	6.00	5.25	4.38	5.75	4.25	4.38	.28 x 1.25	1B	14.5
1000	636-1211-000	11	6.75	5.25	4.38	5.75	4.25	4.38	.28 x 1.25	1B	19.0
1500	636-1221-000	11	6.00	6.75	5.97	6.25	4.50	5.75	.44 x 1.50	1B	24.0
2000	636-1231-000	11	7.50	6.75	5.97	7.12	5.38	5.75	.44 x 1.50	1B	34.0
3000	636-1241-000	11	8.88	6.75	5.97	8.88	7.13	5.75	.44 x 1.50	1B	43.0
5000	636-1261-000	11	10.00	9.00	7.88	7.88	6.13	7.75	.44 x 0.69	1B	76.0

Group 2: Terminal Type

115°C Temperature Rise • Class 180°C Insulation • 50/60 Hz

VA	Catalog Number	Fig.	Depth A (in.)	Length B (in.)	Height C (in.)	Mounting D	Mounting Center E	Mounting Center F	Mounting Slot GXH	Wiring Diagram	Est. Ship Wgt. (lbs.)
208/277 V – 120 V											
750	636-1206-000	11	6.00	5.25	4.38	5.75	4.25	4.38	.28 x 1.25	2	14.5
1000	636-1216-000	11	6.75	5.25	4.38	5.75	4.25	4.38	.28 x 1.25	2	19.0
1500	636-1226-000	11	6.00	6.75	5.97	6.25	4.50	5.75	.44 x 1.50	2	24.0
2000	636-1236-000	11	7.50	6.75	5.97	7.12	5.38	5.75	.44 x 1.50	2	34.0
3000	636-1246-000	11	8.88	6.75	5.97	8.88	7.13	5.75	.44 x 1.50	2	43.0
5000	636-1266-000	11	10.00	9.00	7.88	7.88	6.13	7.75	.44 x 0.69	2	76.0

Group 3: Terminal Type

115°C Temperature Rise • Class 180°C Insulation • 50/60 Hz

VA	Catalog Number	Fig.	Depth A (in.)	Length B (in.)	Height C (in.)	Mounting D	Mounting Center E	Mounting Center F	Mounting Slot GXH	Wiring Diagram	Est. Ship Wgt. (lbs.)
415/600, 400/575, 380/550, 500 V – 120, 115, 110, 100 V											
750	636-1208-000	11	6.00	5.25	4.38	5.75	4.25	4.38	.28 x 1.25	3	14.5
1000	636-1218-000	11	6.75	5.25	4.38	5.75	4.25	4.38	.28 x 1.25	3	19.0
1500	636-1228-000	11	6.00	6.75	5.97	6.25	4.50	5.75	.44 x 1.50	3	24.0
2000	636-1238-000	11	7.50	6.75	5.97	7.12	5.38	5.75	.44 x 1.50	3	34.0
3000	636-1248-000	11	8.88	6.75	5.97	8.88	7.13	5.75	.44 x 1.50	3	43.0
5000	636-1268-000	11	10.00	9.00	7.88	7.88	6.13	7.75	.44 x 0.69	3	76.0

NOTE: Mounting dimensions subject to change without notice. Consult website or factory where dimension verification is critical. For other voltage groups and sizes under 750 VA, refer to UniCap section.



200 Series

- For 2-pole units, add –200 to the suffix above. Example: 636-1208-200
- The primary fuse block adds 1.25 inches to Dimension C.

300 Series

- For 3-pole units, add –300 to the suffix above. Example: 636-1208-300
- The primary fuse block adds 1.25 inches to Dimension C.

400 Series

- For units with 4-pole finger safe terminals, add –400 to the suffix above. Example: 636-1208-400
- The finger-safe terminal block (CE Marked) adds 0.88 inches to Dimension C.
- Dimension A does not apply to this Series.

11

Industrial Control – Core and Coil

Figure 10

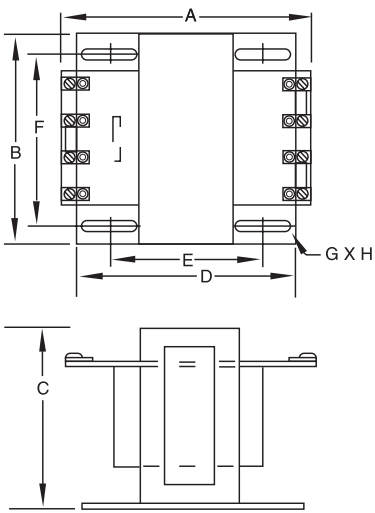
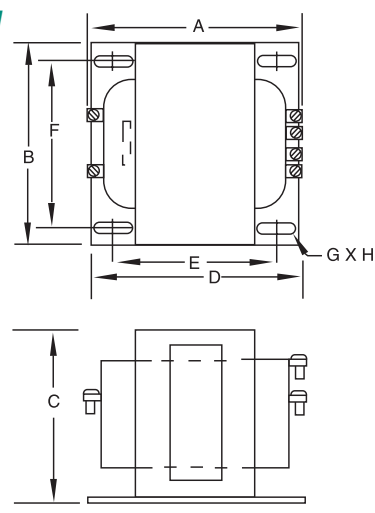
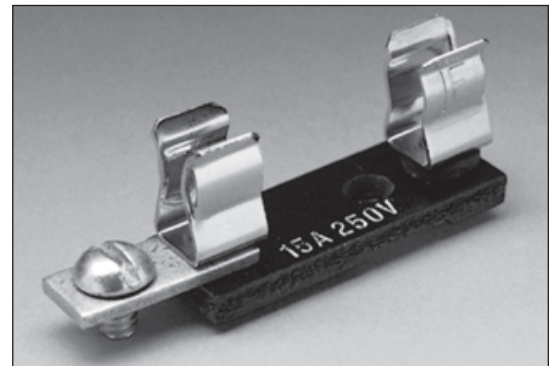

Figure 11



Accessory

Catalog Number	Size	Description	Maximum Rating
636-7412	1.25" x 0.25"	Fuse clip designed for use with standard fuses	15 Amps 250 Volts



Industrial Control – Core and Coil

Group 1A Wiring Diagram & Connections*

Wiring Diagram

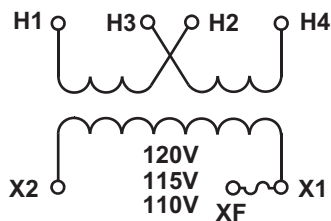

Connections		
Primary Volts	Interconnect	Primary Lines Connect To
240	H1-H3 H2-H4	H1, H4
230	H1-H3 H2-H4	H1, H4
220	H1-H3 H2-H4	H1, H4
480	H3-H2	H1, H4
460	H3-H2	H1, H4
440	H3-H2	H1, H4
Sec. Volts	Secondary Lines Connect To	
120	X2, XF	
115	X2, XF	
110	X2, XF	

Group 1B Wiring Diagram & Connections*

Wiring Diagram

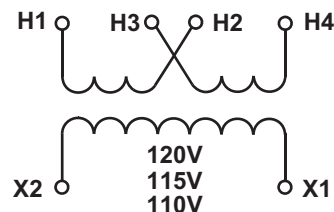

Connections		
Primary Volts	Interconnect	Primary Lines Connect To
240	H1-H3 H2-H4	H1, H4
230	H1-H3 H2-H4	H1, H4
220	H1-H3 H2-H4	H1, H4
480	H3-H2	H1, H4
460	H3-H2	H1, H4
440	H3-H2	H1, H4
Sec. Volts	Secondary Lines Connect To	
120	X2, X1	
115	X2, X1	
110	X2, X1	

Group 2 Wiring Diagram & Connections*

Wiring Diagram

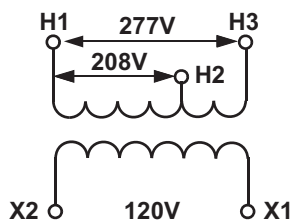

Connections		
Primary Volts	Primary Lines Connect To	
277	H1, H3	
208	H1, H2	
Sec. Volts	Secondary Lines Connect To	
120	X2, X1	

Group 3 Wiring Diagram & Connections*

Wiring Diagram

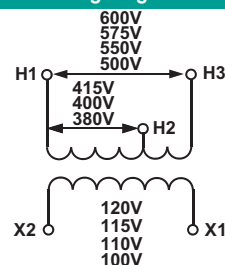

Connections		
Primary Volts	Primary Lines Connect To	
600	H1, H3	
575	H1, H3	
550	H1, H3	
500	H1, H3	
415	H1, H2	
400	H1, H2	
380	H1, H2	
Sec. Volts	Secondary Lines Connect To	
120	X2, X1	
115	X2, X1	
110	X2, X1	
100	X2, X1	

NOTE: Electrostatic shields are optionally available and not shown in all wiring diagrams. * Insulate unused taps individually.

11

Industrial Control – Core and Coil

Notes:

Version JE901 0612 Date Dec 06