



0.050 to 10 KVA

Contents

Overview	9.2
Dimensional Drawings	9.9
Wiring Diagrams	9.10
Selection Charts	
120 x 240 V – 12/24 V 60 Hz	9.8
120 x 240 V – 16/32 V 60 Hz	9.8
240 x 480 V – 24/48 V 60 Hz	9.8

Products

- *Single-Phase Encapsulated: 50 VA through 10 KVA**

Applications

- *For correcting voltage line drops, landscape lighting, low voltage lighting, international voltage adaptation and motor applications*
- *Note: Buck-boost transformers do not compensate for fluctuating line voltages.*

Specifications

- *Encapsulated with electrical grade resin*
- *Cores of high quality electrical steel*
- *NEMA 3R-rated enclosures*
- *135°C temperature rise, 180°C insulation class or 95°C temperature rise, 130°C insulation class depending on kVA size*
- *Heat-cured ASA-61 gray powder coat finish*

Features, Functions, Benefits

- *Slotted mounting holes for quick and easy mounting*
- *Convenient wall mount design with lifting hooks above 5 KVA*
- *Permanently affixed wiring diagram*

Standards

- *Built in accordance with NEMA, ANSI, UL and CSA standards*

***Options and Accessories**

- *CE Marked units available as custom*
- *Other sizes and voltages available as custom*

Buck-Boost – Powerformer™

Jefferson Electric single-phase Buck-Boost transformers are the most economical means available for stepping voltages up or down in many common applications. They can be used as isolating (or insulating) transformers for transforming standard line voltages to low secondary voltages. They are also used to buck or boost off-standard line voltages to satisfy standard load voltage requirements when connected in an autotransformer configuration.

These transformers are designed for use on single- or three-phase circuits to supply 12/24 or 16/32 volt secondaries with 120/240 volt primary, and 24/48 volt secondaries with 240/480 volt primary. When connected in an autotransformer configuration, these small, compact and lightweight units will handle a large KVA load in comparison to their physical size and relative cost. When used as isolation transformers, they have innumerable low voltage applications.

The difference between an autotransformer and an isolation transformer.

In an autotransformer, the input (or primary) and the output (or secondary) are electrically connected, while in an isolation transformer they are completely separated, as shown to the right.

Only a portion of the electrical energy is changed in an autotransformer, the remainder flowing directly between the primary and secondary. In an isolation transformer, all the energy is transformed. For these reasons, an autotransformer is smaller, lighter and less costly than a comparable isolation transformer.

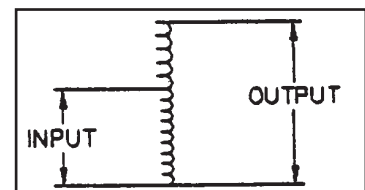

Autotransformer

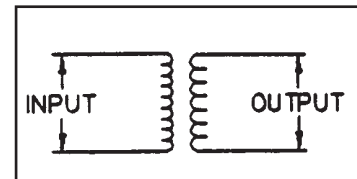

Isolation (or Insulating) Transformer

Solve over/under line voltage problems efficiently and economically.

Electrical equipment is manufactured to operate most efficiently when the line voltage is equal to or nearly equal to the nameplate rating of the equipment. A motor operated at a voltage substantially under its nameplate rating may run constantly on the starting windings, resulting in overheating and possible burn-out. The same motor operated at a voltage substantially over its nameplate rating is subject to excessive heat rise, often extending beyond the insulation temperature limits, which may eventually cause the motor to burn out.

Caution: Buck-Boost transformers will not compensate for fluctuating line voltages. They should only be used when line voltage is relatively constant.

How to Use the Buck-Boost Rapid Selector Charts:

You will need the following information:

Line voltage:

This can be determined by measuring the supply line voltage with a voltmeter.

Load voltage:

The voltage at which your equipment was designed to operate. Usually listed on the equipment nameplate.

Load KVA or load amps:

One of these will usually be listed on the nameplate. You do not need both.

Supply line and equipment frequencies:

This will be either 50 or 60 cycles. The supply line frequency must be the same as the frequency of the equipment to be operated.

Supply line and equipment phase:

Either single-phase or three-phase. The line phase must be the same as the equipment.

The type of electrical configuration:

Delta or Wye.

Follow These Five Easy Steps:

1. Find the appropriate single-phase, three-phase delta or three-phase wye table.
2. Read down the voltage column and find the nearest ratio of required load voltage to line voltage for the application desired. (High and low voltage may be either input or output voltage depending on the circumstances.)
3. Reading horizontally across the line beginning with your application voltage ratio, locate in one of the KVA columns a KVA capacity equal to or larger than your load requirement.
4. Note the two digit number at the top of the KVA column listing the KVA capacity you require.
5. In the catalog number column, add these two digits to the catalog number next to the voltage ratio you found in step one.

Example:

(Assume the following information)

1. A reasonably constant line voltage of 440 volts.
2. A required equipment voltage of 480 volts.
3. 26.0 KVA load capacity needed.
4. Single-phase line and equipment.

In the voltage column, 437 is closest to our line voltage of 440. The 480 high voltage meets our requirements exactly.

Reading horizontally across this line, find 30.0 KVA, the closest larger KVA to our required 26.0.

Going to the very top of this column, take the two digit number, 81, and add it on the end of the catalog number on the same line as our high/low voltage. The catalog number 416-14, with 81 added on the end, is 416-1481.

The listings here do not cover all the possible applications of these versatile transformers. Please call for advice or a quotation on special applications.

Buck-Boost – Powerformer™

Single-Phase KVA Capacity of Encapsulated Powerformers™

Maximum load capabilities

Low Voltage (LV)	High Voltage (HV)	Catalog Number	Load Required*	01 .100 KVA	11 .150 KVA	21 .250 KVA	31 .500 KVA	41 .750 KVA	51 1.0 KVA	61 1.5 KVA	71 2.0 KVA	81 3.0 KVA	91 5.0 KVA	Wiring Diagram
95	120	416-12	KVA	.37	.56	.94	1.8	2.8	3.7	5.6	7.5	11.2	18.8	2
			AMPS	3.95	5.93	9.89	19.7	29.6	39.5	59.3	79.1	118	197	
100	120	416-11	KVA	.50	.75	1.25	2.50	3.7	5.0	7.5	10.0	15.0	25.0	2
			AMPS	5.0	7.5	12.5	25.0	37.0	50.0	75.0	100	150	250	
106	120	416-12	KVA	.75	1.12	1.87	3.7	5.6	7.5	11.2	15.0	22.5	37.0	1
			AMPS	7.07	10.5	17.6	34.9	52.8	70.7	105	141	212	349	
109	120	416-11	KVA	1.00	1.50	2.50	5.0	7.5	10.0	15.0	20.0	30.0	50.0	1
			AMPS	9.17	13.7	22.9	45.8	68.8	91.7	137	183	275	458	
120	132	416-11	KVA	1.10	1.65	2.75	5.5	8.2	11.0	16.5	22.0	33.0	55.0	1
			AMPS	9.17	13.7	22.9	45.8	68.8	91.7	137	183	275	458	
120	136	416-12	KVA	.85	1.27	2.12	4.2	6.3	8.5	12.7	17.0	25.5	42.0	1
			AMPS	7.08	10.5	17.6	35.0	52.5	70.8	105	141	212	350	
120	144	416-11	KVA	.60	.90	1.50	3.0	4.5	6.0	9.0	12.0	18.0	30.0	2
			AMPS	5.0	7.5	12.5	25.0	37.5	50.0	75.0	100	150	250	
120	152	416-12	KVA	.47	.71	1.18	2.3	3.5	4.7	7.1	9.5	14.2	23.0	2
			AMPS	3.91	5.91	9.83	19.1	29.1	39.1	59.1	79.1	118	191	
200	240	416-14	KVA	.50	.75	1.25	2.5	3.7	5.0	7.5	10.0	15.0	25.0	2
			AMPS	2.50	3.75	6.25	12.5	18.7	25.0	37.5	50.0	75.0	125	
208	236	416-12	KVA	.73	1.10	1.84	3.6	5.5	7.3	11.0	14.7	22.1	36.8	4
			AMPS	3.53	5.28	8.82	17.4	26.4	35.3	52.8	70.7	106	174	
212	240	416-12	KVA	.75	1.12	1.87	3.7	5.6	7.5	11.2	15.0	22.5	37.0	4
			AMPS	3.53	5.28	8.82	17.4	26.4	35.3	52.8	70.7	106	174	
208	230	416-11	KVA	.95	1.4	2.3	4.7	7.1	9.5	14.3	19.0	28.6	47.6	4
			AMPS	4.58	6.88	11.4	22.9	34.4	45.8	68.8	91.7	137	229	
218	240	416-11	KVA	1.00	1.5	2.5	5.0	7.5	10.0	15.0	20.0	30.0	50.0	4
			AMPS	4.58	6.88	11.4	22.9	34.4	45.8	68.8	91.7	137	229	
225	240	416-12	KVA	1.5	2.25	3.75	7.5	11.2	15.0	22.5	30.0	45.0	75.0	3
			AMPS	6.66	10.0	16.6	33.3	49.7	66.6	100	133	200	333	
230	276	416-14	KVA	.57	.86	1.43	2.8	4.3	5.7	8.6	11.5	17.2	28.7	2
			AMPS	2.50	3.75	6.25	12.5	18.7	25.0	37.5	50.0	75.0	124	
240	252	416-11	KVA	2.1	3.15	5.25	10.5	15.7	21.0	31.5	42.0	63.0	105	3
			AMPS	8.75	13.1	21.8	43.7	65.4	87.5	131	175	262	437	
240	264	416-11	KVA	1.1	1.65	2.75	5.5	8.2	11.0	16.5	22.0	33.0	55.0	4
			AMPS	4.58	6.87	11.4	22.9	34.1	45.8	68.7	91.6	137	229	
240	272	416-12	KVA	.85	1.27	2.12	4.2	6.3	8.5	12.7	17.0	25.5	42.0	4
			AMPS	3.54	5.29	8.83	17.5	26.2	35.4	52.9	70.8	106	175	
240	288	416-14	KVA	.60	.90	1.50	3.0	4.5	6.0	9.0	12.0	18.0	30.0	2
			AMPS	2.5	3.75	6.25	12.5	18.7	25.0	37.5	50.0	75.0	125	
437	480	416-14	KVA	1.00	1.50	2.50	5.0	7.5	10.0	15.0	20.0	30.0	50.0	4
			AMPS	2.28	3.43	5.72	11.4	17.1	22.8	34.3	45.7	68.6	114	
457	480	416-14	KVA	2.0	3.0	5.0	10.0	15.0	20.0	30.0	40.0	60.0	100	3
			AMPS	4.37	6.56	10.9	21.8	32.8	43.7	65.6	87.5	131	218	
480	504	416-14	KVA	2.1	3.15	5.25	10.5	15.7	21.0	31.5	42.0	63.0	105	3
			AMPS	4.37	6.56	10.9	21.8	32.8	43.7	65.6	87.5	131	218	
480	528	416-14	KVA	1.1	1.65	2.75	5.5	8.2	11.0	16.5	22.0	33.0	55.0	4
			AMPS	2.29	3.43	5.72	11.4	17.0	22.9	34.3	45.8	68.7	114	

* Load required is calculated based on the low voltage as the load.

Buck-Boost Wiring Diagram 1

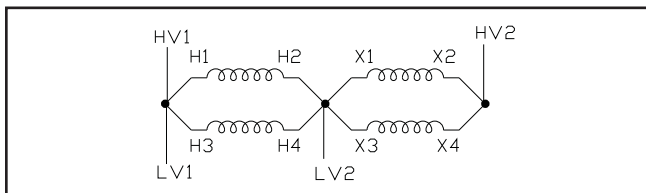

Buck-Boost Wiring Diagram 2

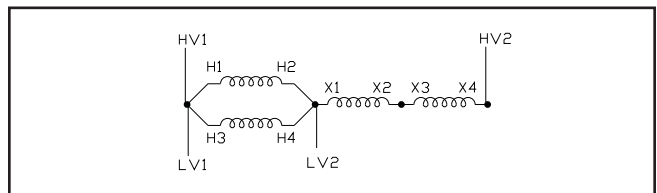

Buck-Boost Wiring Diagram 3

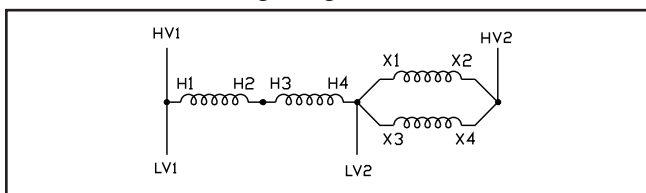

Buck-Boost Wiring Diagram 4

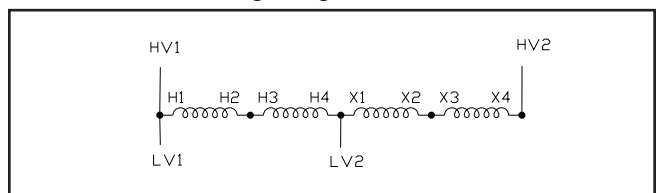

Three-Phase KVA Capacity of Encapsulated Powerformers™ Connected in Open-Delta

Maximum load capabilities requiring two Powerformers

Low Voltage (LV)	High Voltage (HV)	Catalog Number	Load Required*	01 .100 KVA	11 .150 KVA	21 .250 KVA	31 .500 KVA	41 .750 KVA	51 1.0 KVA	61 1.5 KVA	71 2.0 KVA	81 3.0 KVA	91 5.0 KVA	Wiring Diagram
200	240	416-14xx	KVA	0.86	1.29	2.1	4.3	6.4	8.6	12.9	17.2	25.0	43.0	10
			Amperes	2.1	3.1	5.1	10.3	15.4	20.7	31.0	41.4	60.1	103.4	
208	236	416-12xx	KVA	1.27	1.91	3.1	6.3	9.5	12.7	19.1	25.5	38.2	63.7	12
			Amperes	3.1	4.7	7.6	15.4	23.2	31.1	46.7	62.4	93.4	155.8	
212	240	416-12xx	KVA	1.29	1.94	3.2	6.4	9.7	12.9	19.4	25.8	38.0	64.0	12
			Amperes	3.1	4.7	7.7	15.4	23.3	31.0	46.7	62.1	91.4	154.0	
208	230	416-11xx	KVA	1.65	2.47	4.1	8.2	12.3	16.5	24.7	33.0	49.5	82.5	12
			Amperes	4.1	6.2	10.3	20.6	30.9	41.4	62.0	82.8	124.3	207.1	
218	240	416-11xx	KVA	1.73	2.59	4.3	8.6	12.9	17.3	25.9	34.6	51.0	86.0	12
			Amperes	4.2	6.2	10.3	20.7	31.0	41.6	62.3	83.2	122.7	206.9	
225	240	416-12xx	KVA	2.59	3.89	6.4	12.9	19.4	25.9	38.9	51.9	77.0	129	11
			Amperes	6.2	9.4	15.4	31.0	46.7	62.3	93.6	124.8	185.2	310.3	
229	240	416-11xx	KVA	3.46	5.18	8.6	17.3	25.9	34.6	51.8	69.2	103	173	11
			Amperes	8.3	12.5	20.7	41.6	62.3	83.2	124.6	166.5	247.8	416.2	
230	253	416-14xx	KVA	1.81	2.72	4.5	9.0	13.6	18.1	27.2	36.3	54.0	90.0	9
			Amperes	4.1	6.2	10.3	20.5	31.0	41.3	62.1	82.8	123.2	205.4	
230	276	416-14xx	KVA	0.99	1.49	2.4	4.9	7.4	9.9	14.9	19.9	29.0	49.0	10
			Amperes	2.1	3.1	5.0	10.2	15.5	20.7	31.2	41.6	60.7	102.5	
240	252	416-11xx	KVA	3.64	5.47	9.1	18.2	27.2	36.4	54.7	72.8	109	182	11
			Amperes	8.3	12.5	20.8	41.7	62.3	83.4	125.3	166.8	249.7	417.0	
240	264	416-11xx	KVA	1.9	2.86	4.7	9.5	14.2	19.0	28.6	38.1	57.0	95.0	12
			Amperes	4.2	6.3	10.3	20.8	31.1	41.6	62.5	83.3	124.7	207.8	
240	272	416-12xx	KVA	1.47	2.2	3.6	7.3	11.0	14.7	22.0	29.4	44.1	73.6	12
			Amperes	3.1	4.7	7.6	15.5	23.3	31.2	46.7	62.4	93.6	156.2	
240	288	416-14xx	KVA	1.03	1.55	2.5	5.1	7.7	10.3	15.5	20.7	31.0	51.0	10
			Amperes	2.1	3.1	5.0	10.2	15.4	20.6	31.1	41.5	62.1	102.2	
437	480	416-14xx	KVA	1.73	2.59	4.3	8.6	12.9	17.3	25.9	34.6	51.0	86.0	12
			Amperes	2.1	3.1	5.2	10.3	15.5	20.8	31.2	41.6	61.3	103.4	
457	480	416-14xx	KVA	3.46	5.18	8.6	17.3	25.9	34.6	51.8	69.2	103	173	11
			Amperes	4.2	6.2	10.3	20.8	31.2	41.6	62.3	83.2	123.9	208.1	
480	504	416-14xx	KVA	3.64	5.47	9.1	18.2	27.2	36.4	54.7	72.8	109	183	11
			Amperes	4.2	6.3	10.4	20.8	31.2	41.7	62.7	83.4	124.9	209.6	
480	528	416-14xx	KVA	1.9	2.86	4.7	9.5	14.2	19.0	28.6	38.1	57.0	95.0	12
			Amperes	2.1	3.1	5.1	10.4	15.5	20.8	31.3	41.7	62.3	103.9	

* Load required is calculated based on the low voltage as the load.

Buck-Boost Wiring Diagram 9

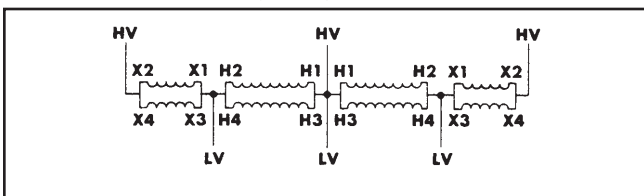

Buck-Boost Wiring Diagram 10

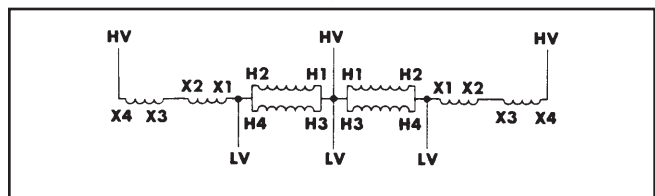

Buck-Boost Wiring Diagram 11

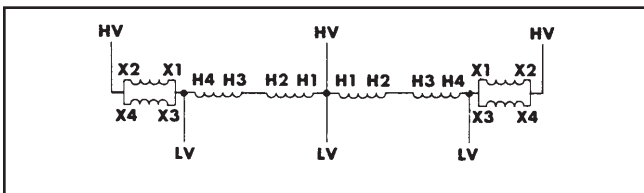

Buck-Boost Wiring Diagram 12

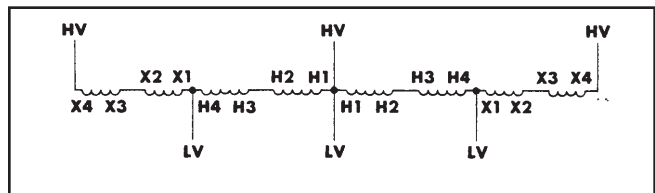

Version JE901 0809 Date Sept.08

Buck-Boost – Powerformer™

Three-Phase KVA Capacity of Encapsulated Powerformers™ Connected in Wye

Maximum load capabilities requiring three Powerformers

Low Voltage (LV)	High Voltage (HV)	Catalog Number	Load Required*	01 .100 KVA	11 .150 KVA	21 .250 KVA	31 .500 KVA	41 .750 KVA	51 1.0 KVA	61 1.5 KVA	71 2.0 KVA	81 3.0 KVA	91 5.0 KVA	Wiring Diagram
164	208	416-12	KVA	1.1	1.7	2.8	5.6	8.4	11.2	16.8	22.0	34.0	56.0	6
			AMPS	3.89	5.89	9.79	18.9	29.4	38.9	58.9	78.9	117	197	
173	208	416-11	KVA	1.5	2.2	3.7	7.5	11.2	15.0	22.5	30.0	45.0	75.0	6
			AMPS	5.0	7.5	12.5	25.0	37.0	50.0	75.0	100	150	250	
183	208	416-12	KVA	2.2	3.3	5.6	11.2	16.8	22.5	33.7	45.0	67.0	112	5
			AMPS	7.07	10.5	17.6	34.9	52.8	70.7	105	141	212	354	
189	208	416-11	KVA	3.0	4.5	7.5	15.0	22.5	30.0	45.0	60.0	90.0	150	5
			AMPS	9.17	13.7	22.9	45.8	68.8	91.7	137	183	275	458	
208	229	416-11	KVA	3.3	4.9	8.2	16.5	24.7	33.0	49.5	66.0	99.0	165	5
			AMPS	9.17	13.7	22.9	45.8	68.8	91.7	137	183	275	458	
208	235	416-12	KVA	2.5	3.8	6.3	12.7	19.1	25.5	38.2	51.0	76.5	127	5
			AMPS	7.08	10.5	17.6	35.0	52.5	70.8	105	141	212	350	
208	249	416-11	KVA	1.8	2.7	4.5	9.0	13.5	18.0	27.0	36.0	54.0	90.0	6
			AMPS	5.0	7.5	12.5	25.0	37.5	50.0	75.0	100	150	250	
208	263	416-12	KVA	1.4	2.1	3.5	7.1	10.6	14.2	21.4	28.0	42.0	71.0	6
			AMPS	3.91	5.91	9.83	19.1	29.1	39.1	59.1	79.1	118	191	
346	416	416-14	KVA	1.5	2.2	3.7	7.5	11.2	15.0	22.5	30.0	45.0	75.0	6
			AMPS	2.5	3.75	6.25	12.5	18.5	25.0	37.5	50.0	75.0	125	
367	416	416-12	KVA	2.2	3.3	5.6	11.2	16.8	22.5	33.7	45.0	67.0	112	8
			AMPS	3.53	5.28	8.82	17.4	26.4	35.3	52.8	70.7	106	174	
378	416	416-11	KVA	3.0	4.5	7.5	15.0	22.5	30.0	45.0	60.0	90.0	150	8
			AMPS	4.58	6.88	11.4	22.9	34.4	45.8	68.8	91.7	137	229	
390	416	416-12	KVA	4.5	6.7	11.2	22.5	33.7	45.0	67.5	90.0	135	225	7
			AMPS	6.66	10.0	16.6	33.3	49.7	66.6	100	133	200	333	
397	416	416-11	KVA	6.0	9.0	15.0	30.0	45.0	60.0	90.0	120	180	300	7
			AMPS	8.73	13.1	21.8	43.6	65.5	87.3	131	174	262	436	
398	438	416-14	KVA	3.1	4.7	7.8	15.7	23.6	31.5	47.2	63.0	94.0	157	5
			AMPS	4.56	6.82	11.3	22.6	33.9	45.6	68.2	91.3	136	229	
398	478	416-14	KVA	1.7	2.5	4.3	8.6	12.9	17.2	25.9	34.0	51.0	86.0	6
			AMPS	2.50	3.75	6.25	12.5	18.7	25.0	37.5	50.0	75.0	125	
416	437	416-11	SKVA	6.3	9.4	15.7	31.5	47.2	63.0	94.5	126	189	315	7
			AMPS	8.75	13.1	21.8	43.7	65.4	87.5	131	175	262	437	
416	443	416-12	KVA	4.8	7.2	12.0	24.0	36.0	48.0	72.0	96.0	144	240	7
			AMPS	6.66	10.0	16.6	33.3	50.0	66.6	100	133	200	333	
416	457	416-11	KVA	3.3	4.9	8.2	16.5	24.7	33.0	49.5	66.0	99.0	165	8
			AMPS	4.58	6.87	11.4	22.9	34.1	45.8	68.7	91.6	137	229	
416	471	416-12	KVA	2.5	3.8	6.3	12.7	19.1	25.5	38.2	51.0	76.5	127	8
			AMPS	3.54	5.29	8.83	17.5	26.2	35.4	52.9	70.8	106	175	
416	498	416-14	KVA	1.8	2.7	4.5	9.0	13.5	18.0	27.0	36.0	54.0	90.0	6
			AMPS	2.5	3.75	6.25	12.5	18.7	25.0	37.5	50.0	75.0	125	

* Load required is calculated based on the low voltage as the load.

Buck-Boost Wiring Diagram 5

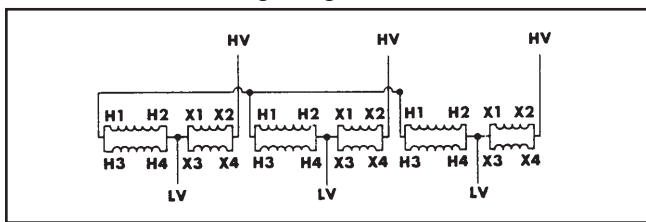

Buck-Boost Wiring Diagram 6

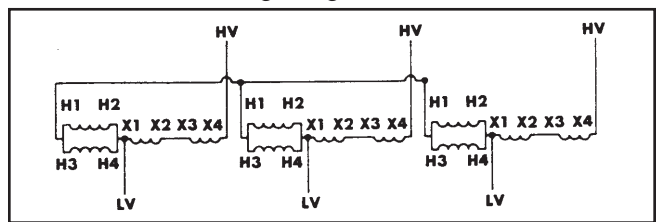

Buck-Boost Wiring Diagram 7

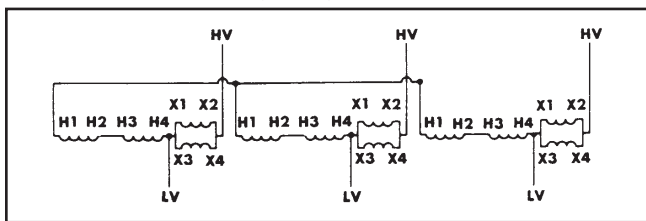

Buck-Boost Wiring Diagram 8

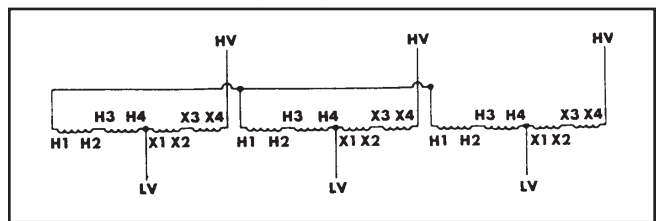

Version JE901 0809 Date Sept 08

Single-Phase - 600V Class

.050 – 1 KVA: 130°C Insulation Class • 1.5 – 10 KVA: 180°C Insulation Class

KVA	Catalog Number	Fig.	Height A (in.)	Width B (in.)	Depth C (in.)	Wiring Diagram	Est. Ship Wgt. (lbs.)	
120 x 240 V – 12/24 V 60 Hz								
.050	416-1100-000	2	8.03	3.31	3.08	S240B	4.4	
.100	416-1101-000	2	8.03	3.31	3.08		4.8	
.150	416-1111-000	2	8.03	3.31	3.08		5.6	
.250	416-1121-000	2	8.03	3.31	3.08		6.7	
.500	416-1131-000	2	10.19	5.06	4.59		15.0	
.750	416-1141-000	2	10.19	5.06	4.59		17.0	
1	416-1151-000	2	10.19	5.06	4.59		19.5	
1.5	416-1161-000	3	12.50	6.69	5.34		35.0	
2	416-1171-000	3	12.50	6.69	5.34		41.2	
3	416-1181-000	3	14.56	7.56	7.15		48.0	
5	416-1191-000	3	14.56	7.56	7.15		90.5	
7.5	416-2101-000	4	16.12	13.50	8.55		130.0	
10	416-2111-000	4	16.12	13.50	8.55		158.0	
120 x 240 V – 16/32 V 60 Hz								
.100	416-1201-000	2	8.03	3.31	3.08	S240C	4.8	
.150	416-1211-000	2	8.03	3.31	3.08		5.6	
.250	416-1221-000	2	8.03	3.31	3.08		6.7	
.500	416-1231-000	2	10.19	5.06	4.59		15.0	
.750	416-1241-000	2	10.19	5.06	4.59		17.0	
1	416-1251-000	2	10.19	5.06	4.59		19.5	
1.5	416-1261-000	3	12.50	6.69	5.34		35.0	
2	416-1271-000	3	12.50	6.69	5.34		41.2	
3	416-1281-000	3	14.56	7.56	7.15		48.0	
5	416-1291-000	3	14.56	7.56	7.15		90.5	
7.5	416-2201-000	4	16.12	13.50	8.55		130.0	
10	416-2211-000	4	16.12	13.50	8.55		158.0	
240 x 480 V – 24/48 Vs 60 Hz								
.100	416-1401-000	2	8.03	3.31	3.08		S480E	4.8
.150	416-1411-000	2	8.03	3.31	3.08	5.6		
.250	416-1421-000	2	8.03	3.31	3.08	6.7		
.500	416-1431-000	2	10.19	5.06	4.59	15.0		
.750	416-1441-000	2	10.19	5.06	4.59	17.0		
1	416-1451-000	2	10.19	5.06	4.59	19.5		
1.5	416-1461-000	3	12.50	6.69	5.34	35.0		
2	416-1471-000	3	12.50	6.69	5.34	41.2		
3	416-1481-000	3	14.56	7.56	7.15	48.0		
5	416-1491-000	3	14.56	7.56	7.15	90.5		
7.5	416-2401-000	4	16.12	13.50	8.55	130.0		
10	416-2411-000	4	16.12	13.50	8.55	158.0		

Note: Housing dimensions subject to change without notice. Contact factory where dimension verification is critical.



Buck-Boost – Powerformer™

Figure 2

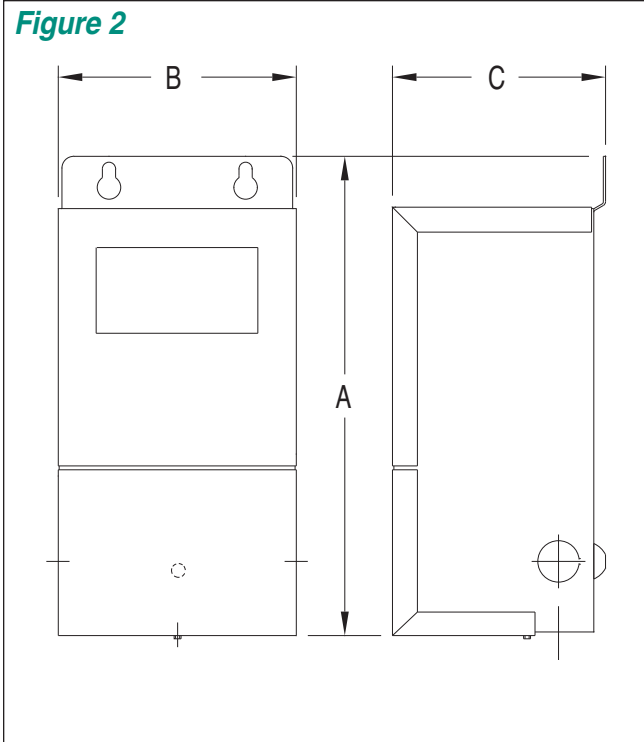

Figure 3

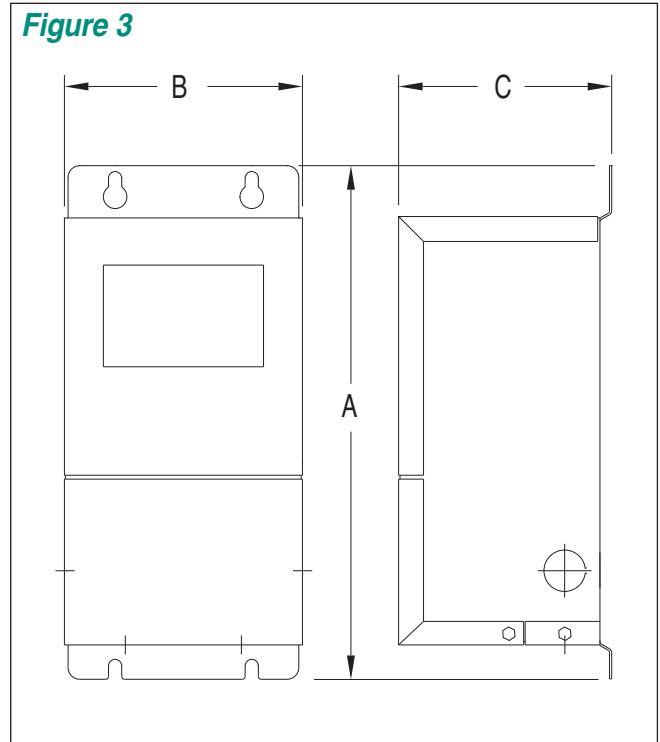
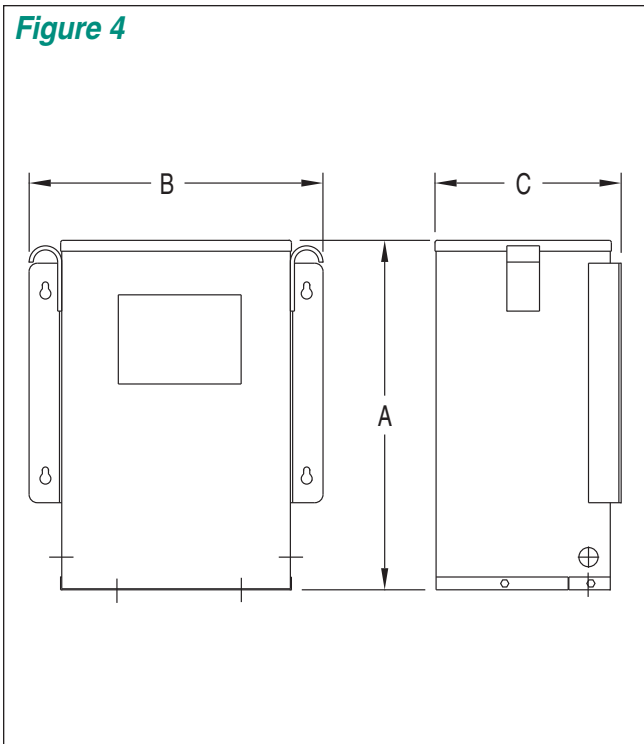

Figure 4



Version JE901 0809 Date Sept 08

9

Buck-Boost – Powerformer™

S240B Wiring Diagram & Connections*

Wiring Diagram

Primary: 120 X 240
Secondary: 12/24

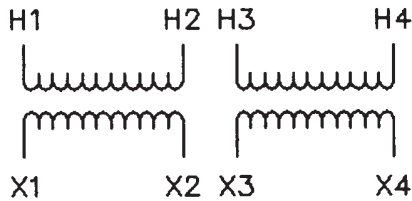

Connections

Primary Volts	Interconnect	Primary Lines Connect To
240	H2 to H3	H1-H4
120	H1 to H3 H2 to H4	H1-H4
Sec. Volts	Interconnect	Secondary Lines Connect To
24	X2 to X3	X1-X4
12	X1 to X3 X2 to X4	X1-X4

S240C Wiring Diagram & Connections*

Wiring Diagram

Primary: 120 X 240
Secondary: 16/32

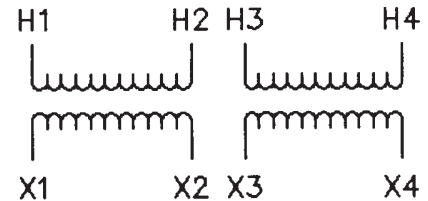

Connections

Primary Volts	Interconnect	Primary Lines Connect To
240	H2 to H3	H1-H4
120	H1 to H3 H2 to H4	H1-H4
Sec. Volts	Interconnect	Secondary Lines Connect To
32	X2 to X3	X1-X4
16	X1 to X3 X2 to X4	X1-X4

S480E Wiring Diagram & Connections*

Wiring Diagram

Primary: 240 X 480
Secondary: 24/48

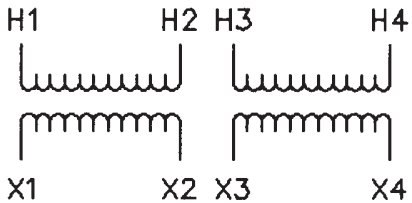

Connections

Primary Volts	Interconnect	Primary Lines Connect To
480	H2 to H3	H1-H4
240	H1 to H3 H2 to H4	H1-H4
Sec. Volts	Interconnect	Secondary Lines Connect To
48	X2 to X3	X1-X4
24	X1 to X3 X2 to X4	X1-X4

NOTE: Electrostatic shields are optionally available and not shown in all wiring diagrams.